

# 45R & 65R COMPRESSOR

## HYDRAULIC ROTARY SCREW



### 45R Compressor Specifications

Output Capacity:	45 cfm @ 100 psi
Max Pressure:	150 PSI
Hydraulic Req:	10-12 gpm @ 2600 psi
Electrical Control:	12 VDC @ 20 amps
Weight:	310 lbs.



### 65R Compressor Specifications

Output Capacity:	65 cfm @ 100 psi
Max Pressure:	150 PSI
Hydraulic Req:	16-18 gpm @ 2600 psi
Electrical Control:	12 VDC @ 20 amps
Weight:	345 lbs.

The 45R & 65R hydraulic-driven rotary screw air compressors are designed for demanding, heavy duty applications. Both the 45R and 65R are designed for 100% continuous duty operation and are great for the heavy equipment mechanic who requires a large volume of air to power a 1" impact wrench and to quickly inflate large tires.

# 45R & 65R HYDRAULIC ROTARY SCREW

## Durability Standard

- The Rotary screw compressor air-end is oil injected to eliminate metal-to-metal contact of the two compressor screw lobes. The result is an air compressor designed for continuous 100% duty cycle with extremely long life.
- The Rotary screw compressor air-end is belt-driven by a heavy-duty hydraulic motor for reliable service.
- Oil/water separation system and oil filtration of the compressor for long life.
- System includes a dual purpose, integral cooler for both

## Ease of Use

- Bulkhead fittings for quick and simplified hook-up (hydraulic supply lines, return lines, and electric power supply connector are all located at one end of the compressor enclosure).
- Includes an attractive powder-coated steel enclosure with a flip-up lid and pneumatic hold-open for easy access to all maintenance points.

the compressor oil and the truck's hydraulic oil. For most applications this eliminates the need for a separate hydraulic oil cooler.....saving you money.

- For safety and reliability the system includes: pressure relief valve, minimum pressure/check valve, automatic air pressure relief upon shutdown and a safety relief.
- Enclosure also includes easy-to-read temperature gauge and hour meter. A resettable safety relay is also conveniently located on the outside of the enclosure.
- Oil level check/refilling is simplified by access from outside the unit.
- Automotive type air cleaner for high capacity and long life.

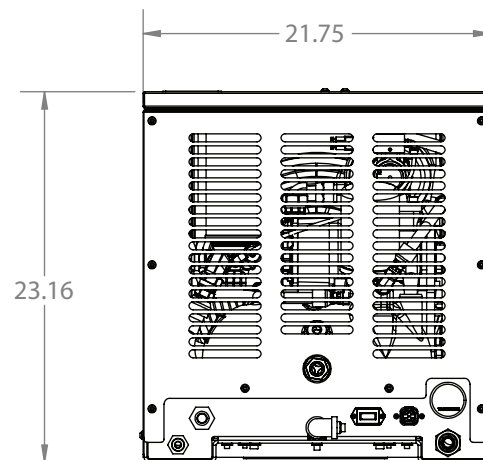
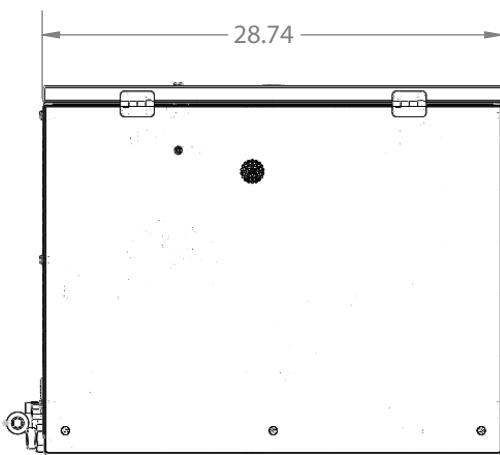

\*Specifications may change without notification.

Your Contact:

**AMERICAN EAGLE**  
**ACCESSORIES GROUP**

Telephone: 800-392-3015  
E-mail: [sales@americaneagleacc.com](mailto:sales@americaneagleacc.com)  
[www.americaneagleacc.com](http://www.americaneagleacc.com)

Designed & Manufactured in the U.S.A.  
Copyright © 2018 American Eagle Accessories Group